

New Generation Digital Cross-connect System

Application
NOTE

Force10's Traverse® Multiservice Transport switch integrates any mix of optional Ethernet, Broadband/HO, and Wideband/LO switching functionality, creating an economical, manageable, and highly scalable New Generation Digital Cross-Connect System solution.

New Generation DCS

The Digital Cross-connect System (DCS or DXC) performs a critical role in a network operator's transport or backhaul network. Designed to optimize network efficiency, these platforms switch and groom bandwidth at multiple levels of granularity for hand-off to the IOF network, or for distribution back into the access network. However, with the increasing capacity demands driven by the influx of new broadband, IP-based access services, scaling legacy DCS/DXC platforms – typically large, power hungry systems that are difficult to manage – becomes increasingly inefficient from both a capital and operational cost perspective.

Force10 Networks eliminates these limitations by building optional wideband/low-order bandwidth management functions directly into the company's industry-leading Traverse Multiservice Transport Switch. Available for a fraction of the cost of a legacy system and allowing you to pay as you grow, this new generation Digital Cross-connect solution offers all the functionality of traditional DCS/DXC, but in a much more economical, versatile and space/ power-efficient form factor. Additionally, the Traverse platform's multiservice design integrates true layer 2 packet switching to support over-subscribed services, along with GFP-enabled support for VLANs, TDM and IP.

A Powerful And Economical Switching Solution

Force10's Traverse™ Multiservice Transport Switch is a true new generation DCS that offers all the functionality of legacy DCS, but in a much more economical, versatile and space/



Traverse 2000 Multiservice Transport Switch

Integrates new generation DCS functions, transport, and Ethernet switching in a compact (1/4 rack high) and economical shelf

Switching matrix scales from 5 to 40 Gbps of capacity by adding modules

Provides a significantly more economical, space efficient, and scalable alternative to legacy DCSs

power efficient form factor. Adding wideband/low-order switching and grooming capabilities to the Traverse platform is as simple as installing an optional VT/TU Switch Module, which provides 5 Gbps of non-blocking VT1.5 and/or VC-11/12 cross-connection capacity. Leveraging the Traverse platform's patent-pending distributed switching architecture, multiple VT/TU Switch Modules can also be installed to enable in-service scalability from 5 to 20 Gbps of switching capacity in a single Traverse 2000 shelf. With the new high density VT Switch and OC-48 modules, any Traverse DCS can be upgraded to support a 40 Gbps switching matrix shelf.

New Generation Digital Cross-connect System

The Traverse platform goes far beyond the capabilities of legacy DCS systems. A single compact platform can also provide high-density electrical, optical and Ethernet access, scalable transport multiplexing and switching – including support for multiple inter-connected OC-192 rings – as well as optional Ethernet switching. As a carrier grade platform, the Traverse supports a variety of protection modes and provides comprehensive cross-connect provisioning and connection management via the intuitive TransNav™ GUI.

Multi-Layer Bandwidth Management

With the seamless integration of wideband DCS capabilities via optional VT Switch Module(s),

the Traverse™ Multiservice Transport Switch creates an advanced multi-layer bandwidth management system that supports true "any to any" cross-connection ability (See Figure 1). Cost-effective expandability makes the Traverse platform ideally suited for DCS/DXC deployments in end-offices, or in hub locations. When deployed as a distributed DCS solution in an end office, the Traverse platform minimizes backhaul bandwidth requirements. In central hub locations, the Traverse platform serves as a highly-scalable and economical alternative to replacing or upgrading legacy cross-connects by switching and grooming traffic between the access network and core service-layer equipment such as Class 5 switches, ATM switches, and routers.

Cost-effective expandability makes the Traverse platform ideally suited for DCS/DXC deployments in end-offices, or in hub locations.

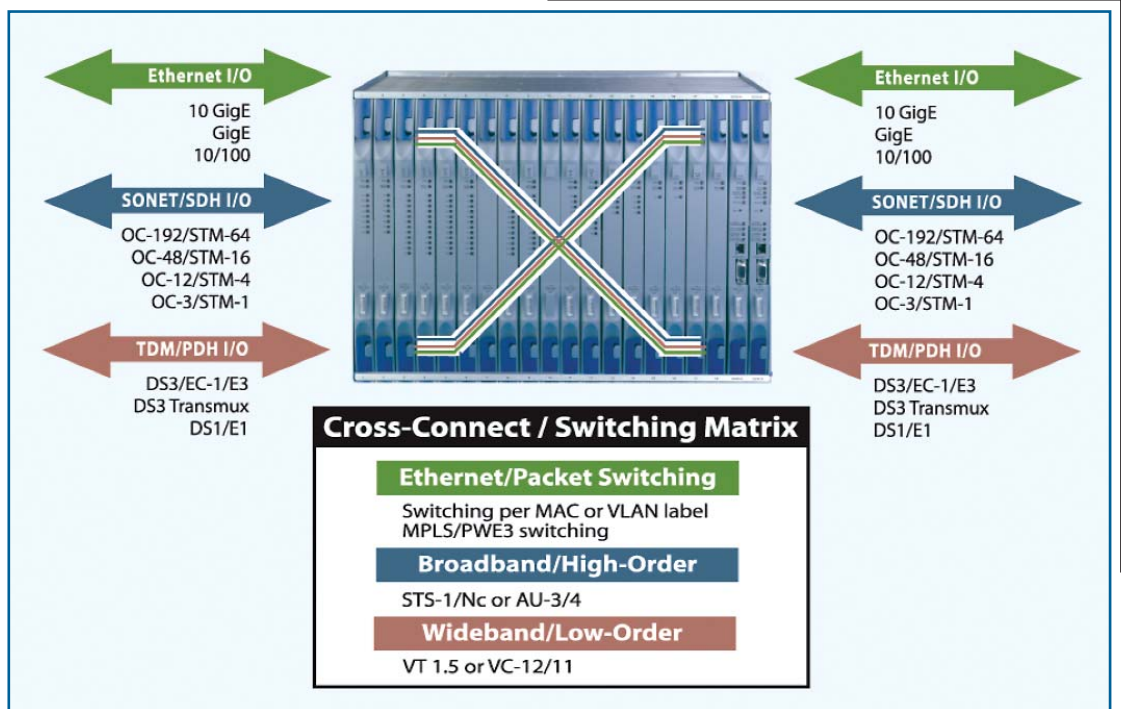

Figure 1: New Generation DCS solution.

New Generation Digital Cross-connect System

Application NOTE

The wideband cross-connect fabric provides wideband/low-order switching functionality across all supported interface types. In addition to supporting standard DCS/DXC features like groom and fill, bridge & roll, and transmuxing the Traverse also supports integrated test access functionality, whereby interoperability with the

Spirent® Network and Centest testers enables carriers to test and monitor any circuit provisioned on the Traverse switch fabric. The Traverse platform is a fully integrated DCS/DXC, SONET/SDH and packet transport solution that simplifies carrier networks, while providing dramatic scalability and cost advantages.

The Traverse platform serves as a highly-scalable and economical alternative to replacing or upgrading legacy cross-connected networks.

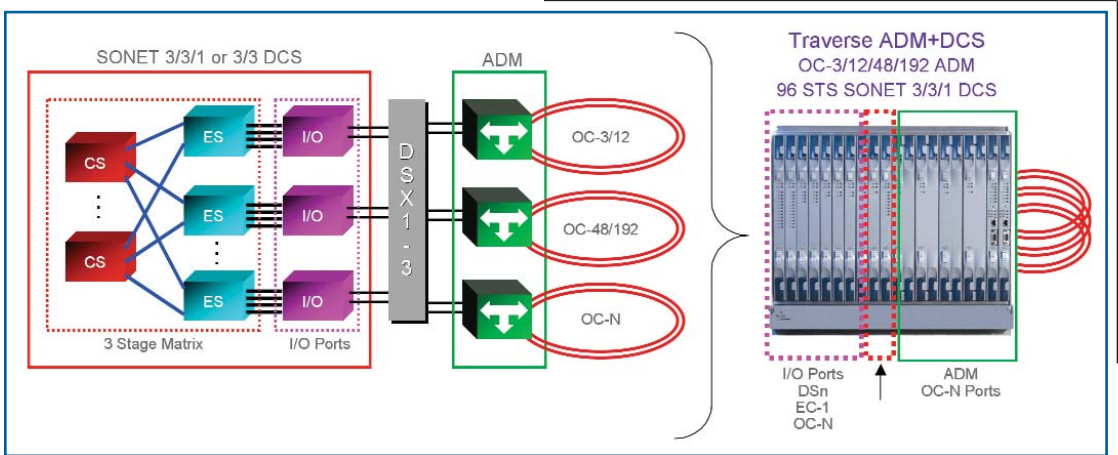

Figure 2: Traverse's Versatility DCS96 Single Integrated ADM+DCS Shelf

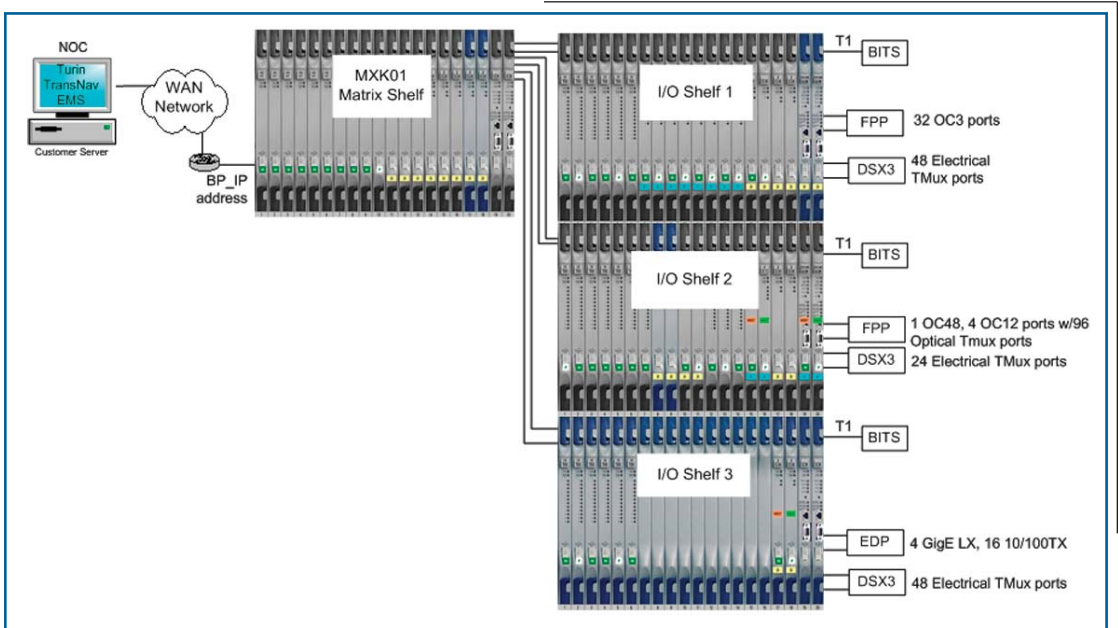

Figure 3: Traverse's Versatile DCS 384 and 768 Matrix and IO Shelves.



Force10 Networks, Inc.
 350 Holger Way
 San Jose, CA 95134 USA
www.force10networks.com

408-571-3500 PHONE
 408-571-3550 FACSIMILE

© 2011 Force10 Networks, Inc. All rights reserved. Force10 Networks, the Force10 Networks logo, Force10, C-Series, E-Series, Traverse, and TraverseEdge are registered trademarks and ExaScale, FTOS, JumpStart, Open Automation, Open Cloud Networking, S-Series, ScriptStore, SmartScripts, SwitchLink, TeraScale, HyperLink, Z-Series, and ZettaScale are trademarks of Force10 Networks, Inc. All other company names are trademarks of their respective holders. Information in this document is subject to change without notice. Certain features may not yet be generally available. Force10 Networks, Inc. assumes no responsibility for any errors that may appear in this document.

AN16

1011 v1.5