

The Missing Piece of Virtualization

**I/O Virtualization on 10 Gb Ethernet
For Virtualized Data Centers**

Agenda

- **10 GbE Adapters Built for Virtualization**
- **I/O Throughput: Virtual & Non-Virtual Servers**
- **Case Study: Cost of Virtualizing 32 Apps**
- **What is IOV (I/O Virtualization)?**
- **IOV Benchmarks Demo**
- **Conclusion**

Eliminating Performance Bottleneck in Virtualized Data Centers

10 Gigabit Ethernet built for I/O Virtualization



I/O Throughput in Virtualized & Non-Virtualized Servers

The Problem:

Virtualization impacts I/O Throughput

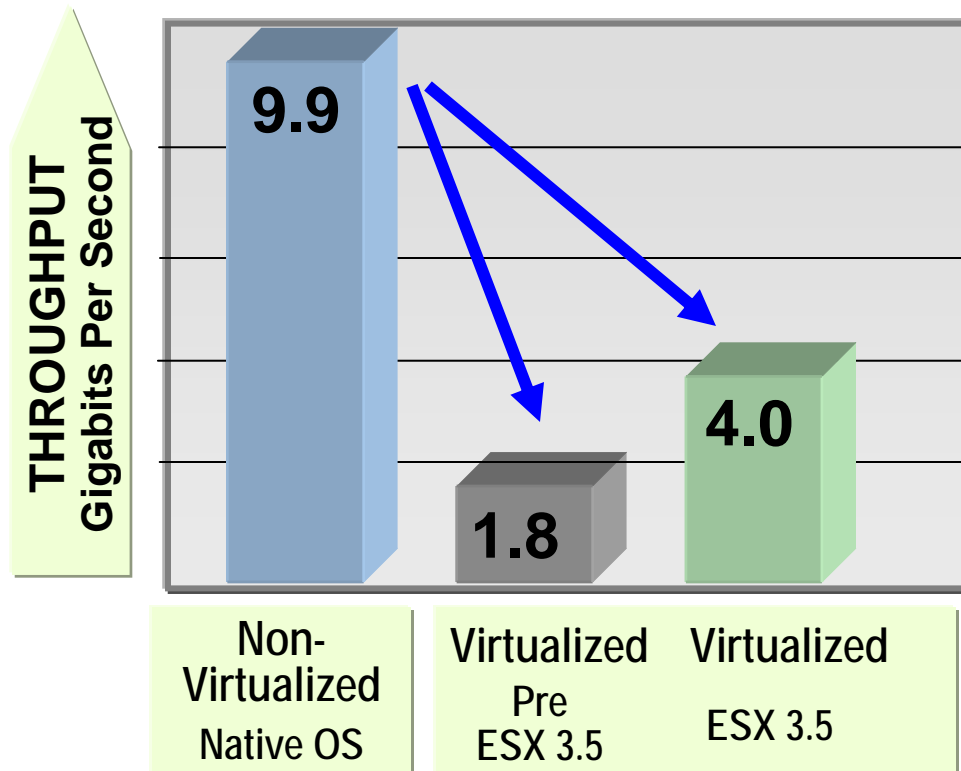

Virtualization

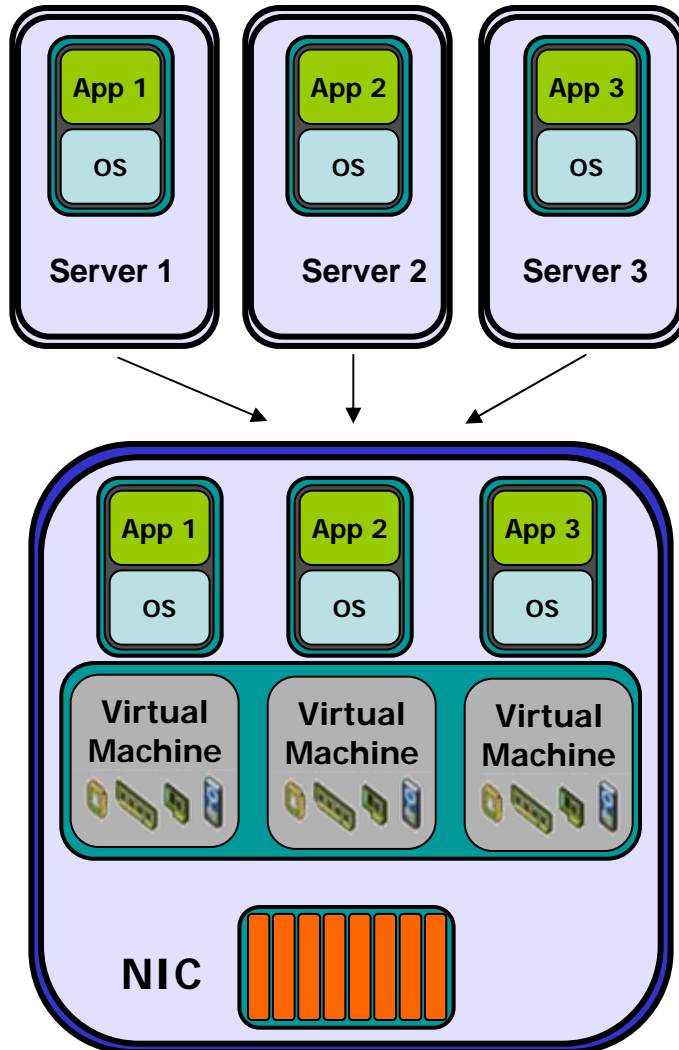

Lower cost method to scale data centers

Higher Resource Utilization

Breakthrough capabilities for x86, held by mainframes

Ecosystem is ready:

- Hypervisors
- Multi-core CPUs
- Multi-channel I/O

Neterion & VMware Accelerate I/O Throughput

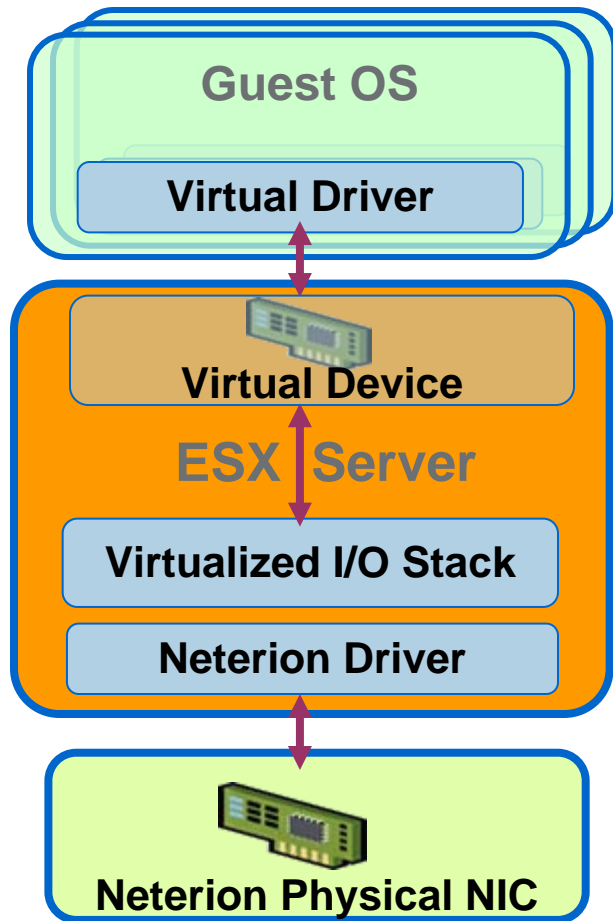

Neterion 10 GE is the only adapter to support VMware NetQueue feature:

- Provides multiple queues
- Each queue associated with MAC address(es)
- MAC address(es) can be changed dynamically without resetting the entire physical NIC
- Each queue is capable of being quiesced independently by hypervisor

IOV will Enable the Virtualization of I/O Intensive Workloads



What is IOV?

- An extension to the PCIe Standard developed by the PCI SIG Work Group
 - Co chaired by HP and IBM
 - Neterion is the only I/O adapter vendor who actively contributed to the development of the specification
 - Investing in IOV architecture since 2001
- IOV divides a physical I/O adapters into many physical independent I/O paths *in silicon*
 - Maximizes throughput
 - Reduces Latency and CPU Utilization
 - Lowest fundamental cost

Two Types of IOV Standards

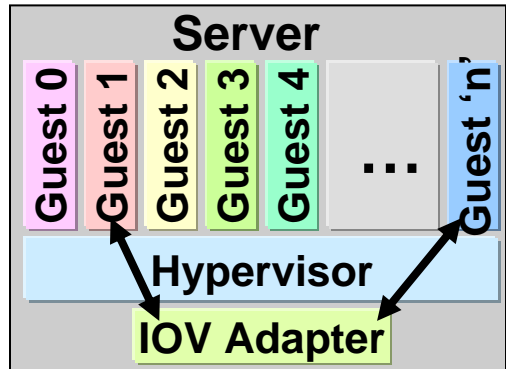

SR-IOV 1.0 Released

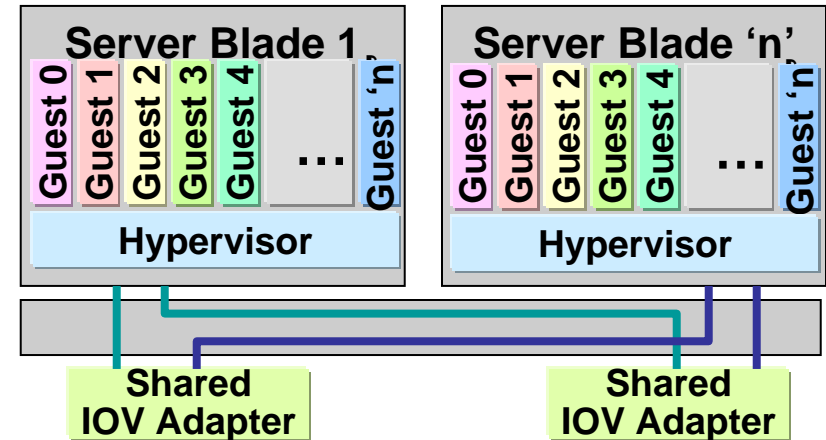

MR-IOV 1.0 In Progress

Single-Root I/O Virtualization

- Multiple Guest OS's in one server share an I/O adapter
- Each Guest OS has its own Virtual slice of an I/O adapter
- VMware, XEN and MS Virtual Servers are SR-IOV capable environments

Multi-Root I/O Virtualization

- Multiple servers share one I/O adapter
- Typically used for server blades
- Sometimes called "Shared I/O"

Neterion IOV 10 GbE Architectural Advantages

Virtual Machines > 1 2 3 4 5 6 7 8 9 10 11 12 13 14 15 16 17

Independent I/O Paths:

- Traffic Isolation:
 - One adapter behaves like multiple physical adapters
 - Independent reset and controls
 - Dedicated MAC address
- Dynamic Provisioning & Bandwidth allocation
- Load Balancing & Failover

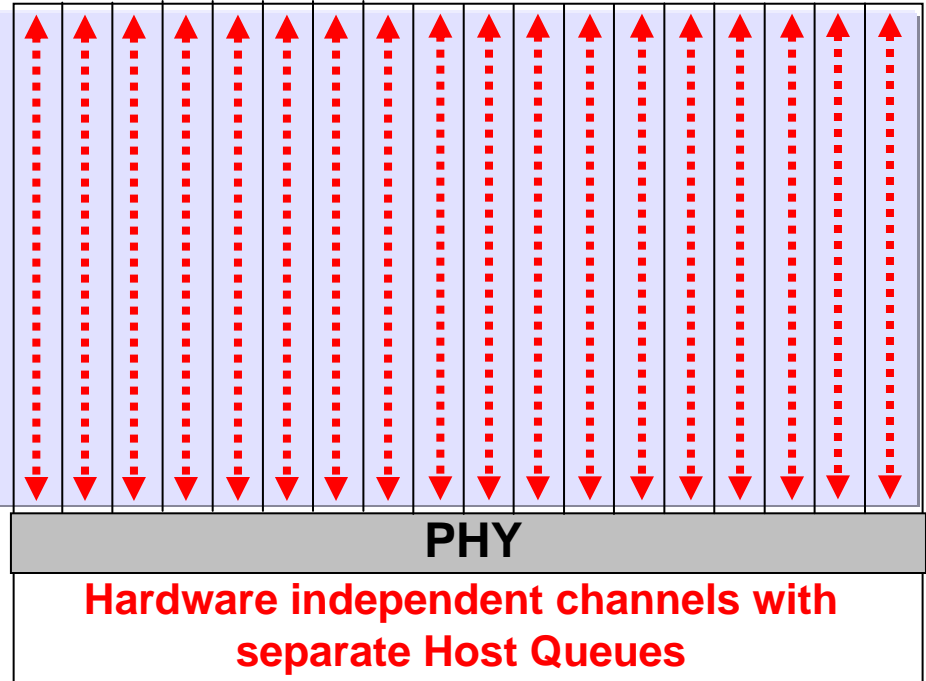

Benefits:

- Eliminate performance bottleneck while preserving management advantages of virtual machines
- Accelerates Mobility and guarantees QoS levels for applications

IOV Architecture – Neterion vs. the competition

Other IOV Front-End

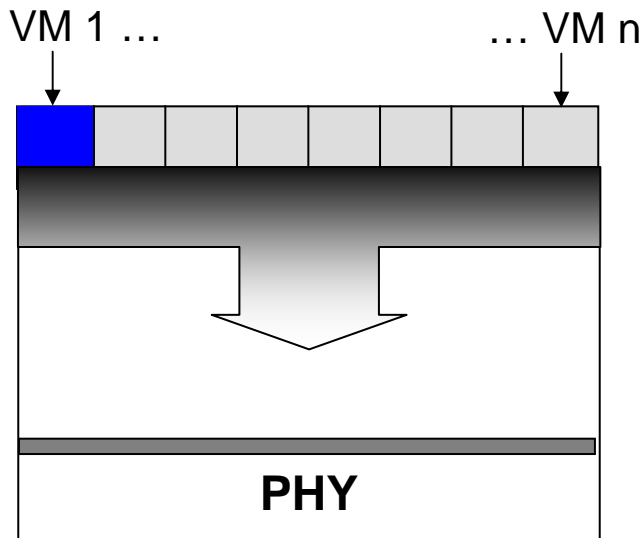

Superficial-layer multi-path:

- Firmware NPU method creates IO bottlenecks
- Congested virtualization, not taking advantage of enhancements to VM architecture

Neterion's Independent Hardware IOV

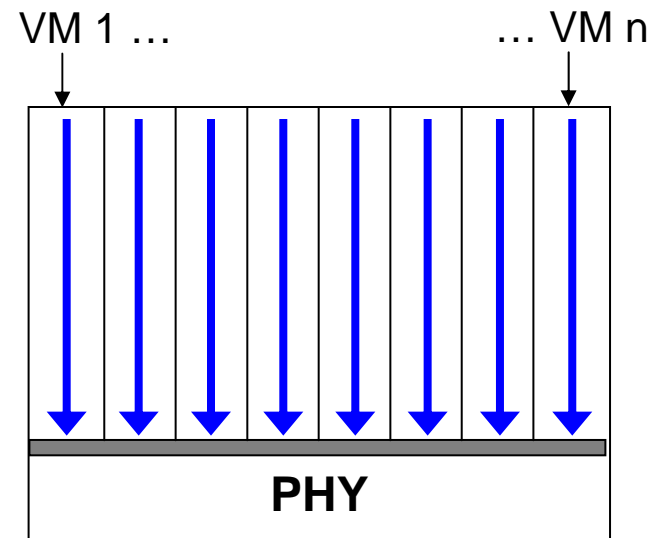

True Hardware-independent paths:

- Presenting independent physical adapters to the VM's
- Separate Rx/Tx, DMA, interrupts
- Maximum VM performance

IOV Delivers Higher Performance for More Apps

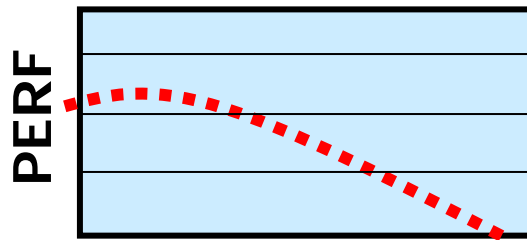
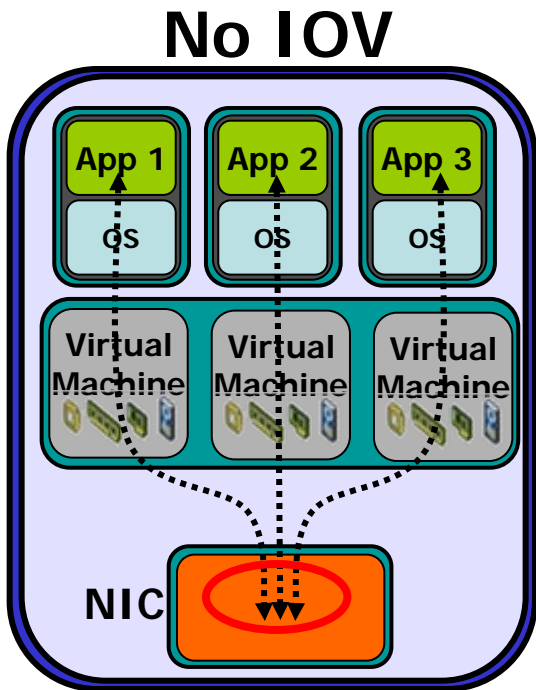

LOAD

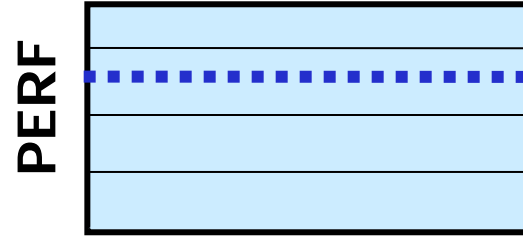
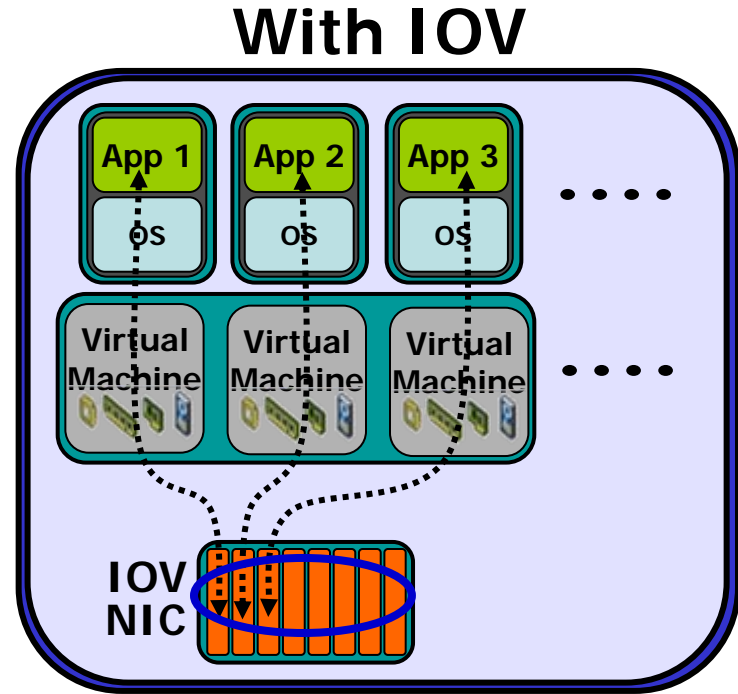

LOAD

Case Study: System-Level Value Proposition

Partial Virtualization of 32 Applications

- 8 are I/O intensive (*Oracle DB, MS Exchange, etc.*)

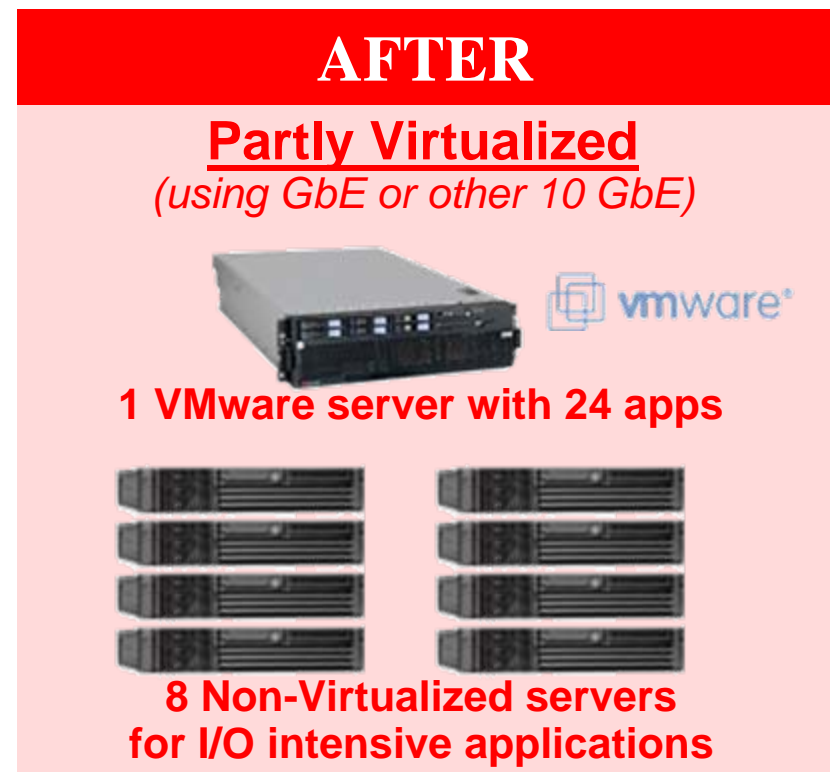
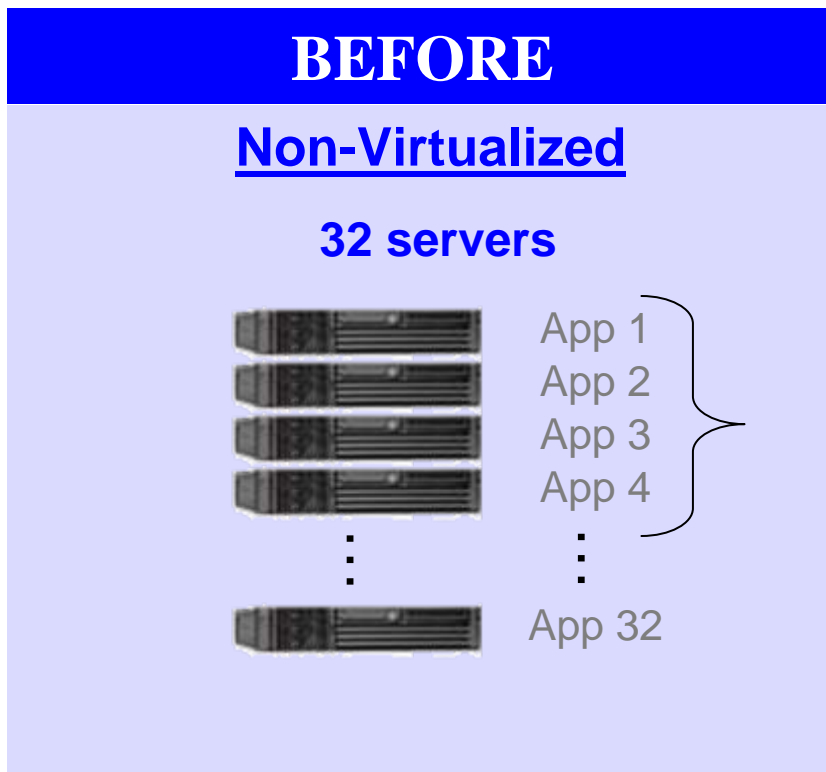

Case Study: System-Level Value Proposition

Full Virtualization of 32 applications with Neterion 10 GbE

- Including 8 I/O intensive (*Oracle DB, MS Exchange, etc.*)

BEFORE

Non-Virtualized

32 servers

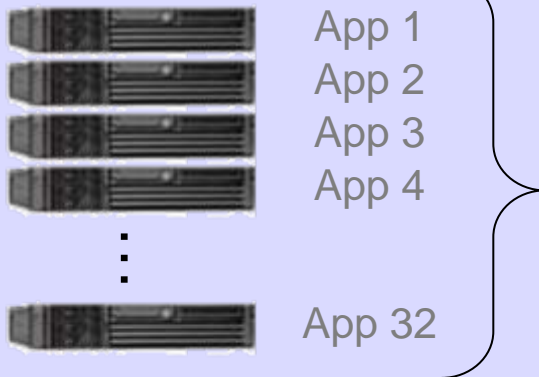

AFTER

Fully Virtualized

(using Neterion Xframe[®] 10 GbE)



1 VMware server with 32 apps

Cost Comparison of Partial and Full Virtualization

	Solution A Partly Virtualized Servers	Solution B Fully Virtualized Server
Configuration	9 Servers (1 x3850 with 24GB RAM + 8 x3250 with 4GB RAM)	1 Server (x3850 with 32GB RAM)
Base systems cost	\$48,000 (1 x \$22K + 8 x \$3K +redundant Ethernet adapters)	\$ 32,000 (System price + redundant Ethernet adapters)
VMware license	\$ 13,500	\$ 9,500
Windows OS license	\$ 3,500	\$ 3,500
Total	\$ 65,000	\$ 45,000

- **Neterion (solutions B) enables all the benefits of virtualization and:**
 - Less upfront (acquisition) cost
 - Less TCO (maintenance) cost
 - Less power, cooling and rack space



ESX Networking Performance: Enabling virtualization of I/O intensive applications

I/O Virtualization is entering a “perfect IOV storm”:

- VMware ESX Server 3.5, with NetQueue feature for I/O throughput improvements
- 16 core systems based on 4-core cpu from Intel and AMD
- PCI-SIG IOV compliant 10GbE adapters like Neterion X3100 Series

ESX 3.5 networking stack achieved 10GbE line rate and throughput parity with non-virtualized operating systems

Neterion IOV-compliant architecture delivers performance breakthrough while preserving all management, protection and QoS levels

Benchmark Demo Setup

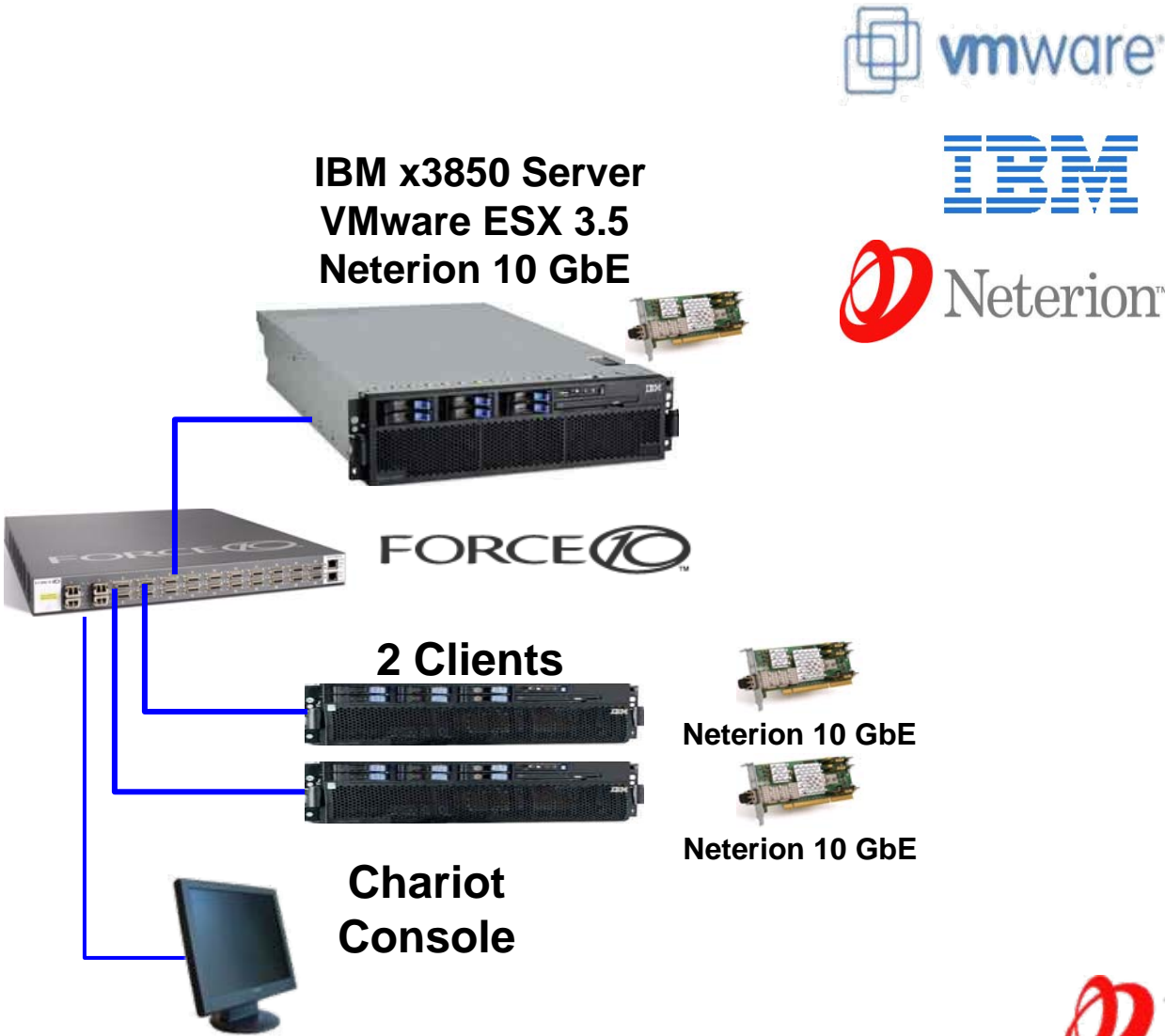

Neterion 10 GbE ESX Transmit Performance

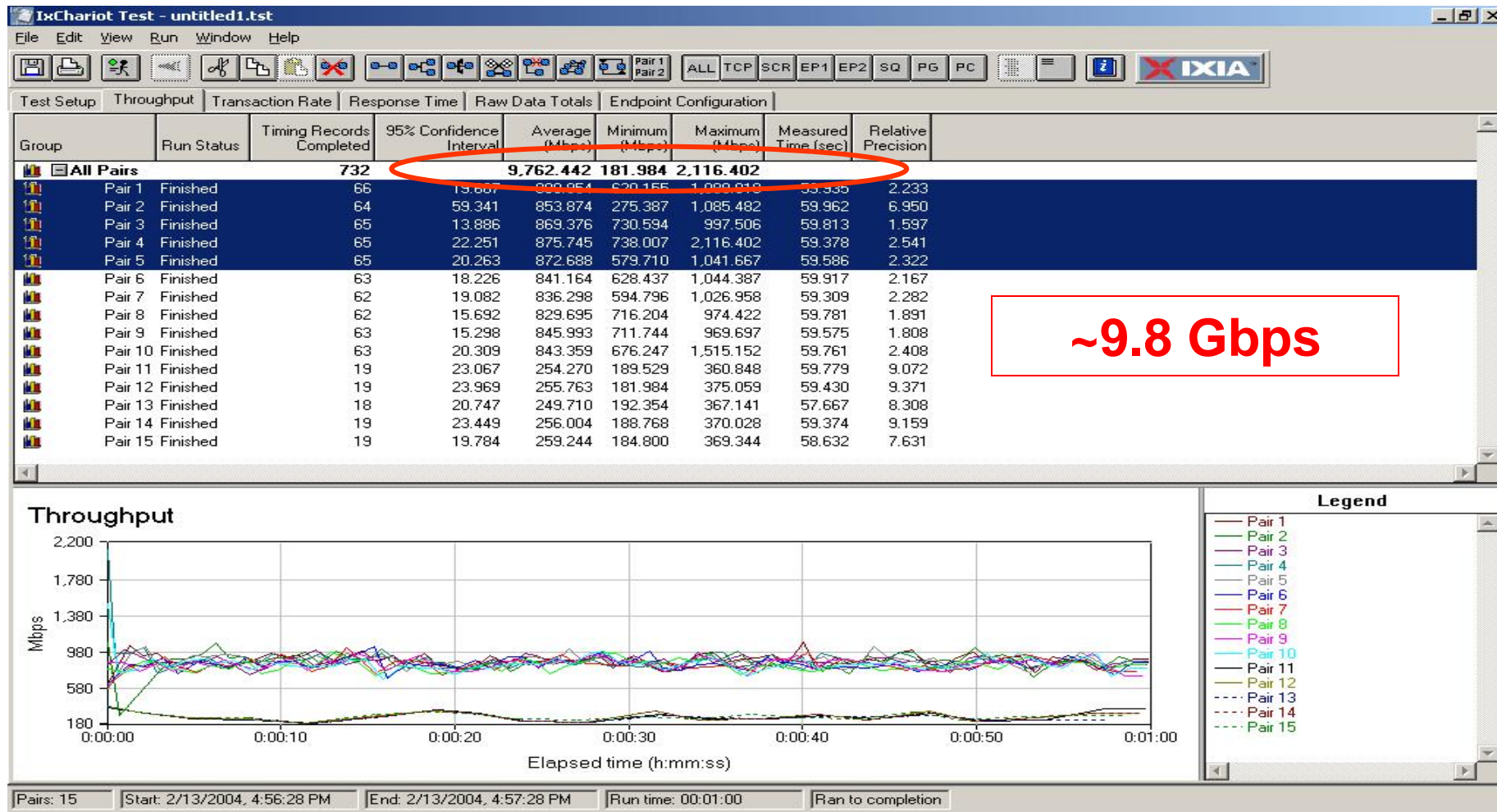

I/O Throughput in Virtualized & Non-Virtualized Servers

Technology Alliance Performance Demo at VMworld, Fall 2007

2007



vmware



Neterion™

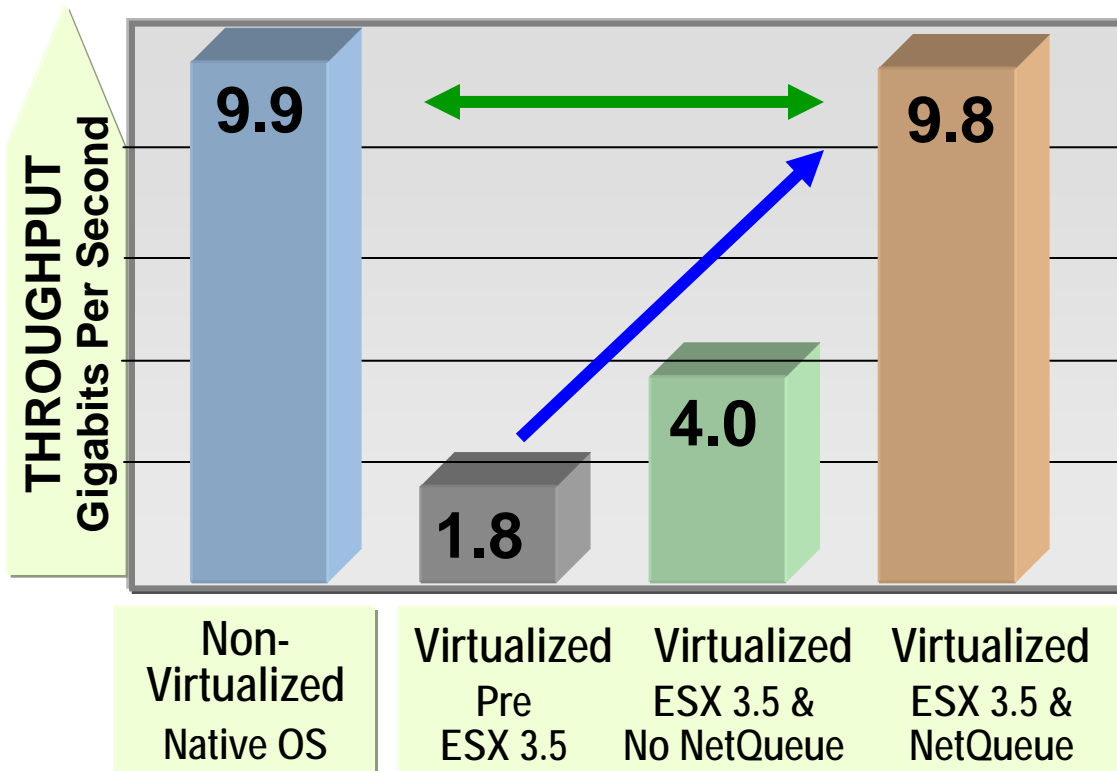

Conclusions:

- Virtualization impacts I/O Performance
- Neterion with NetQueue support delivers:
 - 2.5x to 5x throughput of virtualized servers
 - Matches Non-virtualized throughput

Neterion's I/O Virtualization Leadership

Breakthrough Performance - Comparable to Native OS

Enables Full Virtualization - Reduces cost

Industry First PCI SIG IOV compliant Ethernet Adapter

Enhances Mobility for virtual machines

First 10 GbE in-the-box - VMware ESX 3.5 and Only
Adapter Certified for NetQueue enabled ESX 3.5

First 10 GbE Demonstration of Direct Hardware Access



END